



FRONTIERS IN OPTICAL COHERENT AND ULTRAFast SCIENCE

A NATIONAL SCIENCE FOUNDATION PHYSICS FRONTIER CENTER AT
THE UNIVERSITY OF MICHIGAN AND THE UNIVERSITY OF TEXAS AT AUSTIN

RANDALL LABORATORY, 500 EAST UNIVERSITY, ANN ARBOR, MI 48109-1120

PHONE (734)763-4932 FAX (734)764-5153

<http://www.umich.edu/~focuspc>

DIRECTOR
PHILIP H.
BUCKSBAUM
phb@umich.edu
ASSOC. DIRECTOR
PAUL BERMAN
pberman@umich.edu

ADMINISTRATOR
MICHELLE YOUNG
mamurn@umich.edu

FOCUS COUNCIL
WINTER-SPRING 2006
DUNCAN STEEL
MICHAEL DOWNER
TED NORRIS
CHRIS MONROE
ROBERTO MERLIN

NSF AWARD:
0114336
NSF OFFICER:
DENISE CALDWELL

A nugget from FOCUS:

Implementation of Grover's Quantum Search Algorithm in a Scalable System

K.-A. Brickman, M. Acton, L. Deslauriers, P. C. Haljan, P. J. Lee, and C. Monroe

We report the implementation of the Grover quantum search algorithm with a pair of trapped atomic ion quantum bits [1]. Any of four possible states of the two-qubit memory is marked, and following a single query of the search space, the marked element is successfully recovered with an average probability of 60%. This exceeds the performance of any possible classical search algorithm, which can only succeed on average with a maximum probability of 50%. The main ingredients in the algorithm are the quantum entanglement of trapped cadmium ion qubits through two-qubit logic gates involving the Coulomb-coupled motion of the ions, quantum interference between the amplitudes of the various states, and an efficient quantum measurement of the qubits. The algorithm is realized on the minimum number of elements that show improvement over a classical search, but this implementation is scalable to an arbitrarily large database that would enjoy a quadratic speed up relative to any classical search algorithm, and represents all basic elements of a universal quantum computer with trapped ions.

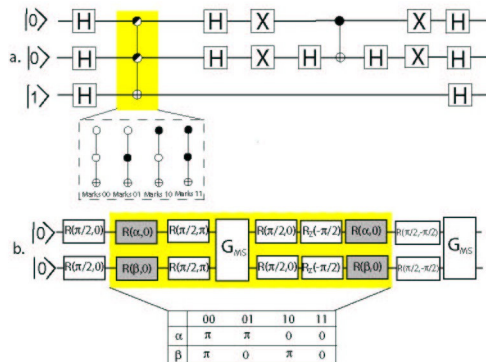

1. Implementation of Grover's Quantum Search Algorithm in a Scalable System, K.-A. Brickman, P. C. Haljan, P. J. Lee, M. Acton, L. Deslauriers, and C. Monroe, *Phys. Rev. A* **72**, 050306R (2005).